

GC10 Reinforced Pitman Arm

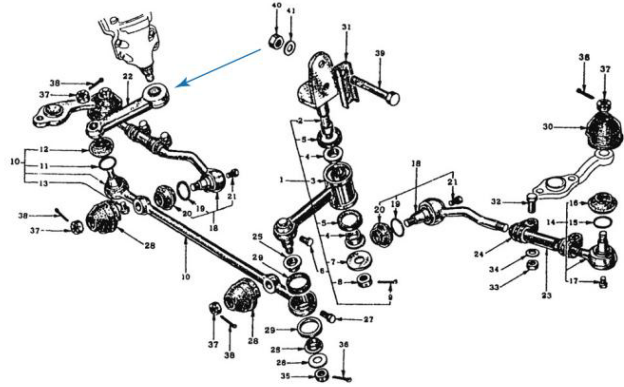

The GC10 genuine pitman arm may have metal fatigue due to years of use, and invisible cracks may be gradually spreading. In order to prevent pitman arm troubles that could lead to accidents with just one mistake, we have developed a new reinforced pitman arm with excellent durability. This product is made with tenacious and crack-resistant chrome molybdenum steel, and has been redesigned to be thicker and wider, with an emphasis on safety.

Price
¥22,000



Reinforced flange

R200 Reinforced side flange (GC10, S30, etc.)



*Difference change from R180 to R200 due to engine power up is a standard for tuning cars. This side flange is always necessary at that time. When Nissan discontinued production of genuine side flange, we reviewed it as a reinforced part and changed the design. Nickel chrome molybdenum steel is used as the material to withstand shock and twisting caused by sudden clutch engagement, and it cleared strict inspection standards for heat treatment and processing precision.

Price
Left and right set **¥39,000**

Subaru R180 reinforced side flange



*This bolt-on side flange allows you to mount the easily available Subaru R180 differential to the S30 and GC10. Unlike the Nissan R180 bolt type (hollow spline), this is a circlip type, which allows the inside of the spline to be solid, increasing strength. Furthermore, the spline diameter is 2mm thicker and reinforced, and the use of high-strength nickel-chrome-molybdenum steel ensures twice the strength of the genuine product.

Price
Left and right set **¥39,000**

R200 Reinforced Companion Flange



This is a companion flange required for mounting the R200 of the Z31 or R31 on a Hakosuka or S30. The conventional round flange, which made it difficult to remove and install the differential in a small space, has been redesigned to a square shape, which has helped improve workability. In addition, the thick design ensures sufficient durability.

Compatible models
GC10, GC110, GC210, R30
S30, S130, KHC130 etc.

Price
¥16,000

*Parts that connect to the propeller shaft. Attached to the front side of the differential.

Nissan R180 Companion Flange



This is a convenient companion flange when loading a SUBARU R180 onto a Hakosuka or S30. The conventional round flange, which made it difficult to install and remove the differential in a small space, has been redesigned to a square shape, which has helped improve workability.

Compatible models
GC10, GC110, GC210, R30
S30, S130, KHC130 etc.

Price
¥16,000

*Parts that connect to the propeller shaft. Attached to the front side of the differential.

R200/R180 Drive shaft bolt nut set



Compatible models
GC10, GC110, GC210, R30
S30, S130, KHC130 etc.

Price
¥10,320/set of 8

*Single item
Bolt **¥1,150**
Nut **¥100**
Spring washer **¥40** (Updated 2026.04.13)

*Nuts and washers can be used for side flanges.

R180 Reinforced Ring Gear Bolt SET (for Nissan Gears)



Compatible models
GC10, GC110, GC210, R30, S30, S130, KHC130 etc.

Price
*R180 reinforced ring gear bolt set - 23.5mm **¥12,000/8 bottles**
*R180 reinforced ring gear bolt SET - 21.5mm **¥12,000/8 bottles**

*Screw size: M10 x P1.25 x neck length

*The flange thickness of LSD varies depending on the manufacturer. Select the bolt head length taking into consideration the thread depth of the ring gear and the flange thickness of the LSD.

Reinforced propeller shaft bolt set



Twice as strong as the original!

The strength standard of 12.9T means that the bolt can be pulled up to 120 kg per square mm without breaking, and can return to its original shape without stretching up to 90% of the tension, or 108 kg. (The limit for genuine products is 60 kg.)

Thread diameter	Pitch	Neck length	Wrench size	Strength standard
M8	1.25	25	M12	12.9T

Price **¥3,000** *Set of 4 with nuts and washers

Compatible models
GC10, GC110, GC210, R30
510, 610, S30, S130, KHC130, B110, B310, etc.

R180 Bolt type change parts



This part changes the circlip type R180 differential to a bolt type, making it compatible with vehicles such as the S30 and GC10.

Compatible models
GC10, GC110, GC210, R30
S30, S130, KHC130 etc.

Price
¥6,000/SET